



Electronic Design & Research
<http://www.vsholding.com>

Technology for people's ideas

100VDC/45A SPST Relay/Switch

D7G100D45/24/24W -Powerful, Fast Solid State Switch

Designed to deliver 20kW of power in microseconds

Features: Utilizes only 8 sq. in. of PCB area and only 2.0" tall
 45A continuously or up to a 200A-pulse in a miniature package
 High sensitivity, even at high switching frequencies
 800A surge current and only 0.008 Ohms on-state resistance

Please specify input control voltage and power supply

Input Specifications:

Input Control Current/Voltage 24VDC/1mA
 Power Supply Voltage/Current 18-36VDC, 20mA

Output Specifications:

Operating DC voltage range 0 – 100 VDC
 Maximum continuous current 40 A
 Maximum Continuous Current 67 A
 Maximum surge current (IDM) - .1mS 800 A
 Maximum pulsing current, duty 1/50 200 A/10mS
 Maximum on-state resistance 0.008 Ohm
 Rising time .180 μ S
 Delay-on time .480 μ S
 Falling time (determined by a load)
 Delay-off time .500 μ S
 Maximum switching frequency 100.00 KHz
 Maximum burst frequency (> 2 min) 200.00 KHz
 Shortest pulse width .6 μ S

General Specifications:

Ambient operating temperature range 45⁰ C to 85⁰ C
 Ambient storage temperature range -55⁰ C to 125⁰ C
 Dielectric Strength input-to-output 2,500Vrms(min)

Mechanical Specifications:

Weight (oz) .2
 Encapsulation Epoxies Etc. 50-2366RFR / 50-2366CFK

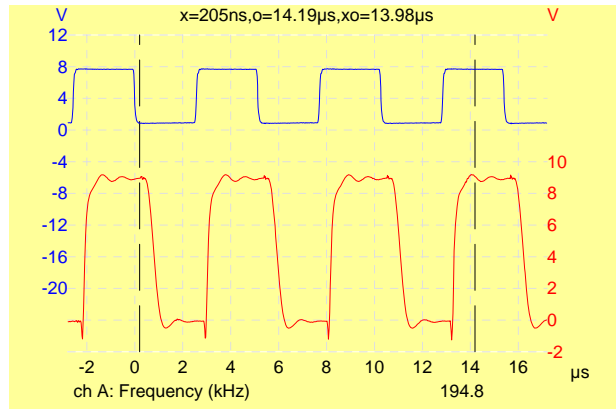
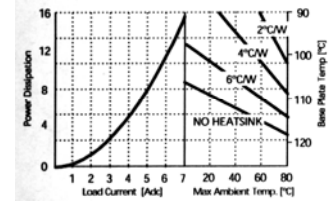
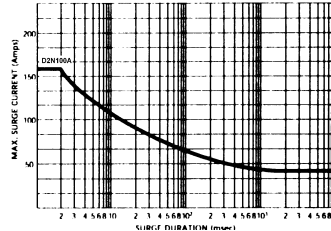

Switching at 194KHz on a 1.0 Ohm load

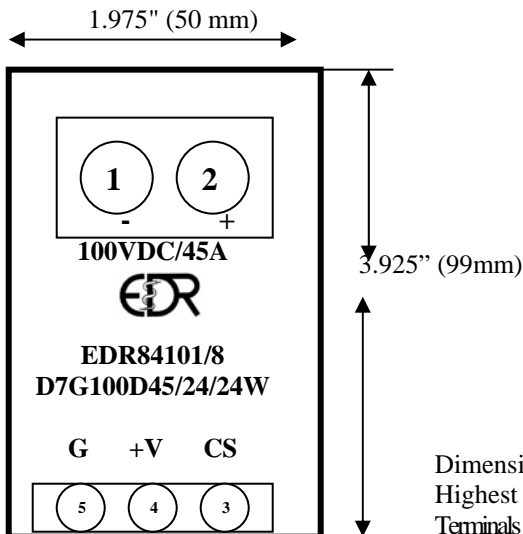

PIN 1: - LOAD
 PIN 2: + LOAD
 PIN 3: + Control Signal
 PIN 4: + Vcc
 PIN 5: GND

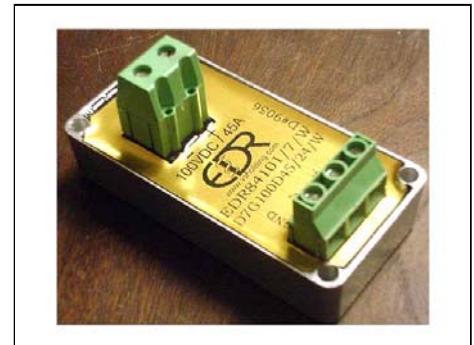

Dimensions of the enclosure (box)
 Highest with Power terminal Block
 Terminals Control (screw type)
 Terminal Power (screw type)

.85"H x 3.925"L x 1.975"W
 2.00"
 wires 10–24AWG
 wire 6-20AWG/rated at 67 Amperes

Transient Protection: All loads are inductive, even ones that are not so obvious or labeled. An inductive load produces a harmful transient voltage, which is much higher than the applied voltage, when it is turned on and off. A SSR built with a MOSFET output acts as an ideal switch and can produce a seemingly "non-inductive" load, which can cause damage if not suppressed. A transient voltage suppressor, which is bi-directional for AC applied voltage and unidirectional for DC applied voltage, should be used to clamp excessive spikes.

Electronic Design & Research Inc. ** 7331 Intermodal Dr. ** Louisville ** KY 40258

Tel: 502-933-8660; Fax: 502-933-3422; Sales: 800-336-1337; e-mail: vsholding@vsholding.com

Input Electrical Characteristics (Ta = 25°C) for DG100D45/24/24W, p/n EDR84101/8

	Minimum	Nominal	Maximum	
Power Supply VDC, Pins 5-6	12	24	36	V
Power Supply, Current	30	20	100/10Khz	mA
“OFF” state, Control Voltage, normally “HIGH”		5		V
“ON” state, Control Voltage, “LOW”		0.8		V
Maximum Input Current, no external resistor			10	mA
An external resistor can be used to decrease the input current			5	mA

Switching time test – Load – 1 Ohm & 20A, a single 1.8 μS pulse width

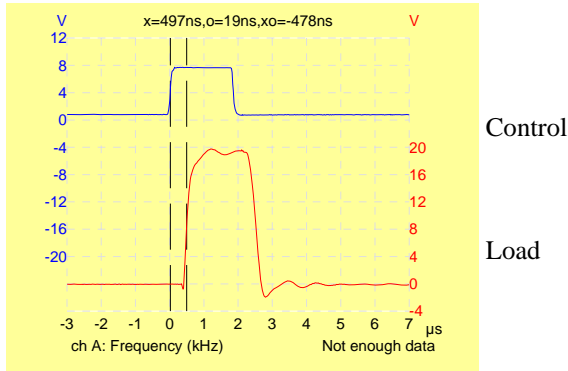

Figure 1 Turn-on delay is .478μS

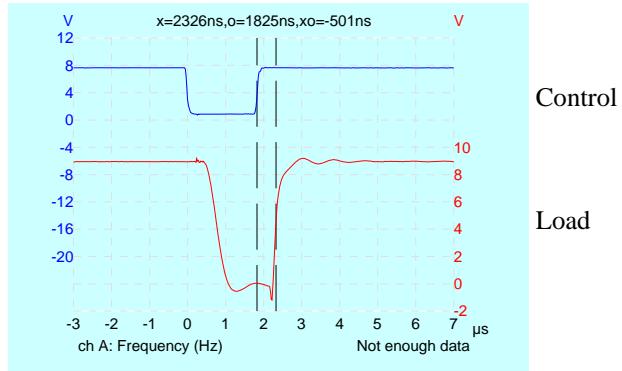

Figure 2 Turn-off delay is .501μS

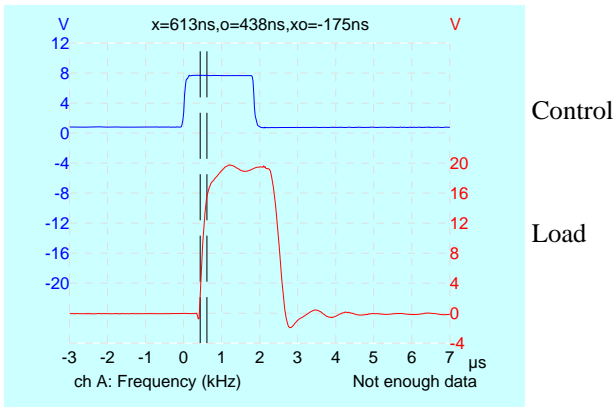

Figure 3 Rising time is 0.175μS

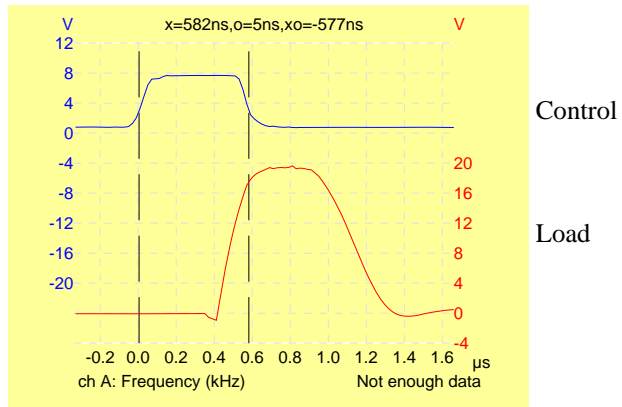
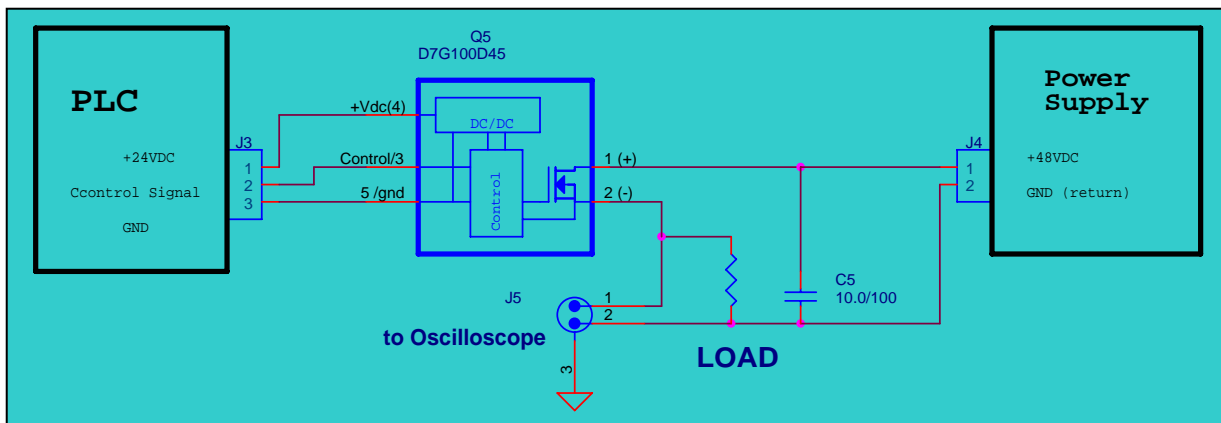

Figure 4 A pulse width is .577μS



Switching Time Test Circuit



Electronic Design & Research
<http://www.vsholding.com>

Technology for people's ideas

100VDC/100A SPST Relay/Switch

D7G100D100/v -Powerful, Fast Solid State Switch

Designed to deliver 80kW of power in microseconds

Features: Utilizes only 8 sq. in. of PCB area and only 2.0" tall
 100A continuously or up to a 800A-pulse in a miniature package
 High sensitivity, even at high switching frequencies
 2500A surge current and only 0.002 Ohms on-state resistance

Please specify input control voltage and power supply

Input Specifications:

Input Control Current 1mA
 Power Supply Voltage/Current 12VDC, 20mA

Output Specifications:

Operating DC voltage range 0 – 100 VDC
 Maximum continuous current 100 A
 Maximum Continuous Current (.1S, 10%) 400 A
 Maximum surge current (IDM) - .1mS 2500 A
 Maximum pulsing current, duty 1/50 800 A/10mS
 Maximum on-state resistance 0.002 Ohm
 Rising time .180 μ S
 Delay-on time .480 μ S
 Falling time (determined by a load)
 Delay-off time .500 μ S
 Maximum switching frequency 100.00 KHz
 Maximum burst frequency (> 2 min) 200.00 KHz
 Shortest pulse width .6 μ S

General Specifications:

Ambient operating temperature range 45⁰ C to 85⁰ C
 Ambient storage temperature range -55⁰ C to 125⁰ C
 Dielectric Strength input-to-output 2,500Vrms(min)

Mechanical Specifications:

Weight (oz) .2
 Encapsulation Epoxies Etc. 50-2366RFR / 50-2366CFK

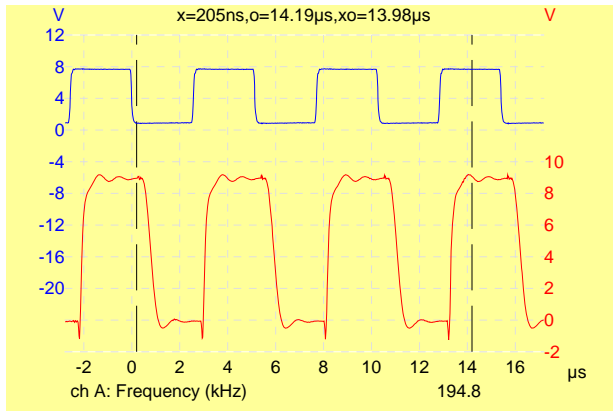
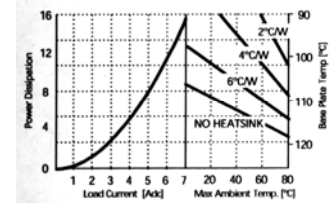
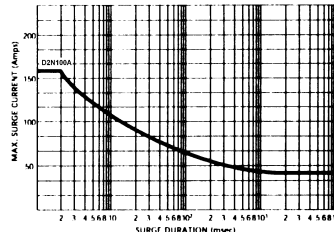

Control
 Load

Switching at 194KHz on a 1.0 Ohm load

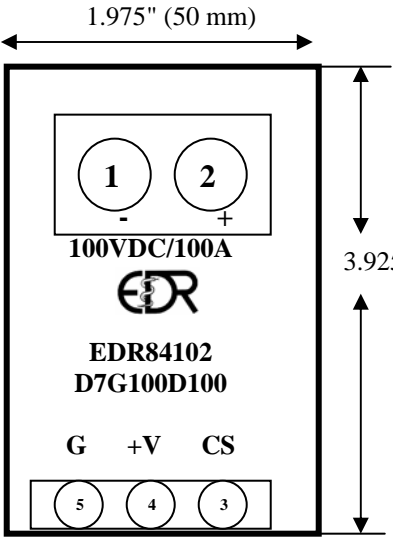

PIN 1: - LOAD
 PIN 2: + LOAD
 PIN 3: + Control Signal
 PIN 4: + Vcc
 PIN 5: GND

Dimensions of the enclosure (box)
 Highest with Power terminal Block
 Terminals Control (screw type)
 Terminal Power (screw type)

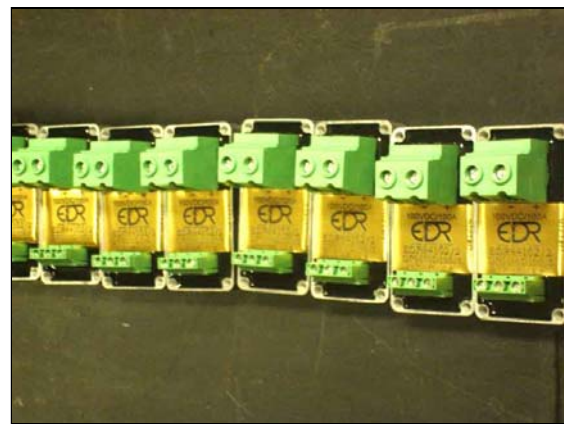

.85"H x 3.925"L x 1.975"W
 2.00"
 wires 10–24AWG
 wire 6-20AWG/rated at 67 Amperes

Transient Protection: All loads are inductive, even ones that are not so obvious or labeled. An inductive load produces a harmful transient voltage, which is much higher than the applied voltage, when it is turned on and off. A SSR built with a MOSFET output acts as an ideal switch and can produce a seemingly "non-inductive" load, which can cause damage if not suppressed. A transient voltage suppressor, which is bi-directional for AC applied voltage and unidirectional for DC applied voltage, should be used to clamp excessive spikes.

Electronic Design & Research Inc. ** 7331 Intermodal Dr. ** Louisville ** KY 40258
 Tel: 502-933-8660; Fax: 502-933-3422; Sales: 800-336-1337; e-mail: vsholding@vsholding.com

Input Electrical Characteristics (Ta = 25°C) for DG100D100/12/24W, p/n EDR84102/8

	Minimum	Nominal	Maximum	
Power Supply VDC, Pins 5-6	12	24	36	V
Power Supply, Current	30	20	100/10Khz	mA
“OFF” state, Control Voltage, normally “HIGH”		5		V
“ON” state, Control Voltage, “LOW”		0.8		V
Maximum Input Current, no external resistor			10	mA
An external resistor can be used to decrease the input current			5	mA

Switching time test – Load – 1 Ohm & 20A, a single 1.8 μS pulse width

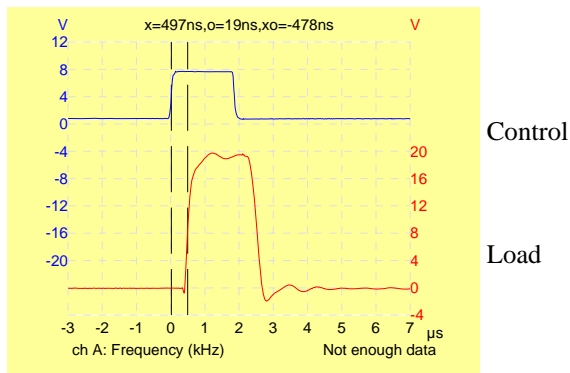

Figure 1 Turn-on delay is .478μS

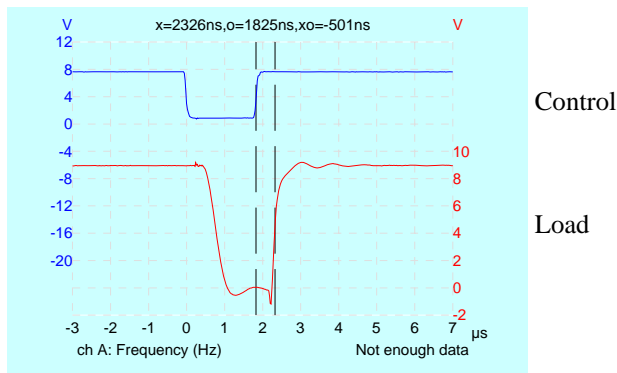

Figure 2 Turn-off delay is .501μS

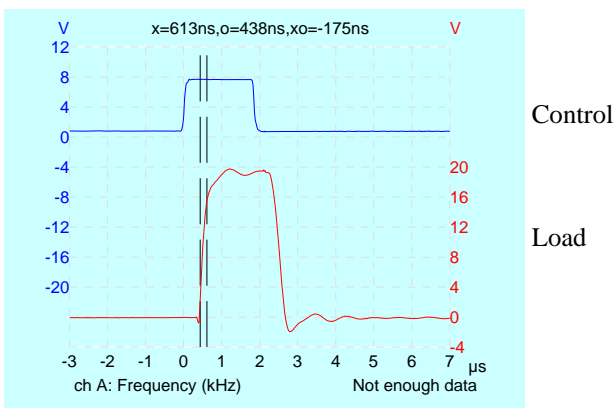

Figure 3 Rising time is 0.175μS

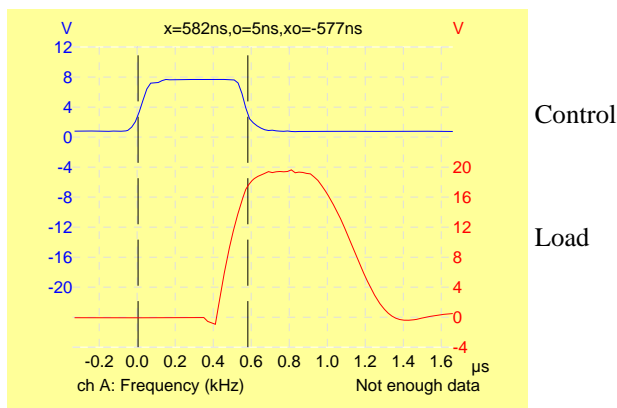
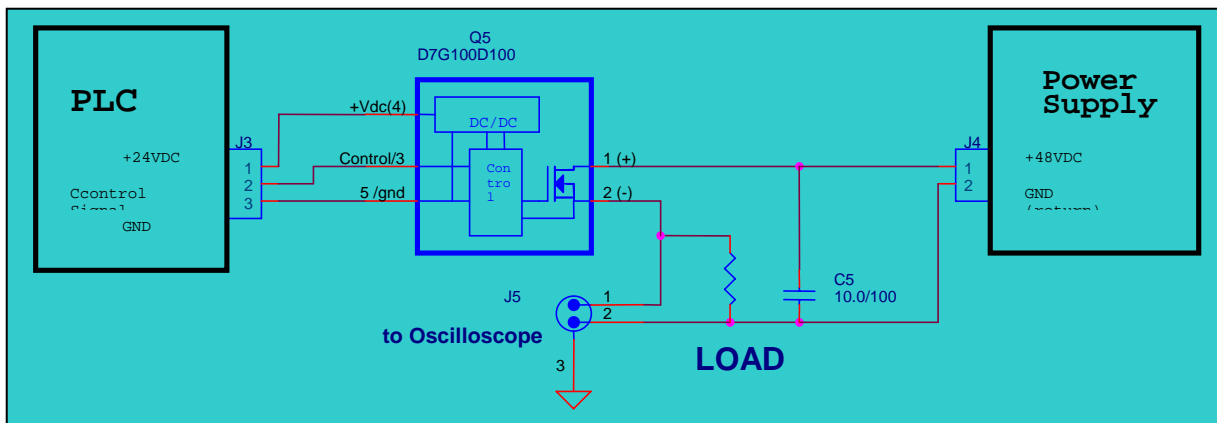

Figure 4 A pulse width is .577μS



Switching Time Test Circuit