



Electronic Design & Research
<http://www.vsholding.com>

Technology for people's ideas

FAST SWITCH

Series D3N Solid State Relay/Switch

15, 20 & 30Amp/40VDC and 11 & 15 Amp/30VAC Output





- * n-MOSFET Output
- * Low On-State Resistance
- * Paralleling Capability
- * Noiseless Operation
- * Voltage Drop Constant with Time
- * Sealed Housing and Weatherproof
- * High speed and low control current
- * No arcing or sparking - Explosive safe
- * Improved Reliability
- * Resistant to shock and vibration
- * Only 1.7" L x 1.15" H x 0.8" W

These solid state DC/AC output relays feature MOSFET technology for low on-state resistance, assuring easy paralleling and switching capabilities. Excellent in noise resistance and input-output separation our devices provide the opportunity to completely separate input/output ground loops and interface different voltage floors. They have no inherent wear-out mechanism and the constant resistance makes it the ultimate replacement choice of a mechanical type relay.

Below are few SSRs from our production line. If your requirement is unique we can produce the custom device you require.

OUTPUT SPECIFICATIONS

(We rated our SSR's for the maximum current without a heat sink.)

Model Number	D3N40D15	D3N40D24	D3N40D30	D3N40A11	D3N40A15
Part Number	EDR82365	EDR82362	EDR82363	EDR82381	EDR82382
					
Control voltage options (Vc)	12 +/-2 VDC		or	21 +/-3 VDC	
Nominal Input Impedance	1 KOhm @ 12VDC		or	2 KOhm @ 24 VDC	
Operating Voltage Range	40 VDC	40VDC	40VDC	40 VDC p-p/30 VAC	
Must operate/release voltages	10VDC/9.6VDC		or	18VDC/17.3VDC	
Max. Load Current Range	0-20 A	0-29 A	0-34 A	0-16 A rms	0-23 A rms
Max. Surge Current, (10mSec)	500 A	800 A	1200 A	400 A	700 A
Max. On-state resistance (Rds-on)	0.007 Ohm	0.0028 Ohm	0.0021 Ohm	0.01 Ohm	0.012 Ohm
Max. Turn-On delay (Operate Time)				5.0 μS	
Rise time				0.5 μS	
Turn-off delay (Release Time)				4.0 μS	
Fall Time				0.6 μS	
Max. switching frequency				25 KHz	
Cost of each at 100 (24VDC input)	\$39.78	\$46.24	\$51.67	\$52.84	\$58.56

The test was performed with Vc=24DC @ 11mA. At 10 KHz a relay current increase to 12 mA. Amb.T = 25°C

Accessory DIN RAIL – p/n EDR82555 and EDR82558

The **EDR82555** and **EDR82558** designed to accommodate D2N and D3N packag and any industrial standard such as IAC, OAC, ODC, D2W, CX and CMX.

The **EDR82558** comes with a de-bouncing circuitry, snubbing network and drivers for easy interfacing with a PLC or any other device with mechanical relays on its output(s).

GENERAL Specifications for a Solid State Relay

Dielectric Strength (input-output)	3000 VDC
Insulation Resistance (Min) @ 500VDC	10 ⁹ Ohm
Ambient Operating Temperature Range	- 30 to +40°C (50% off at 80°C)
Ambient Storage Temperature Range	-45 to +125°C
Weight: (typical)	1.4 oz
Dimensions	1.15"H x 1.75" L x 0.8" W
Encapsulation:	Thermally Conductive Epoxy

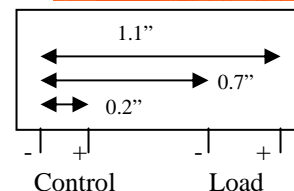

Please call if you need application notes, helps with design, request for a quote or just wants to talk with us.

Electronic Design & Research Inc. ** 7331 Intermodal Drive ** Louisville ** KY 40258

Tel: 502-933-8660; Fax: 502-933-3422; Sales -1-800-336-1337; e-mail: vsholding@vsholding.com



Electronic Design & Research
<http://www.vsholding.com>

Technology for people's ideas

Input Specifications:

Input DC Voltage	12V	24V
Nominal Current	13mA	12mA

45VDC, 24Amp Relay/Switch

Powerful Fast Solid State Relay

Designed to deliver 13KW of power in a few microseconds

- Features:** Utilizes only 1.4 sq. in. of PCB area and only 1.15" tall
 3.2A continuously or up to a 20A-spike in a miniature package
 High sensitivity, even at high switching frequencies
 40A surge current and only 0.2 Ohms on-state resistance

Please specify input control voltage: 12 or 24 VDC

Output Specifications:

Operating DC voltage range	0 – 45VDC
Maximum continuous current	3.2A rms
Maximum surge current (IDM) - 2mS	40A
Continuous current (ID)	20A
Maximum on-state resistance	0.2 Ohm
Rising time	0.6µS
Delay-on time	5.0µS
Falling time	0.3µS
Delay-off time	3.4µS
Maximum switching frequency	25Hz

* Test performed with a D3N650D3/24

General Specifications:

Ambient operating temperature range	-45 ⁰ C to 85 ⁰ C
Ambient storage temperature range	-55 ⁰ C to 125 ⁰ C
Dielectric Strength input-to-output	3,000VAC

Mechanical Specifications:

Weight (oz)	.2
Encapsulation	Epoxies Etc. 50-2366RFR / 50-2366CFR

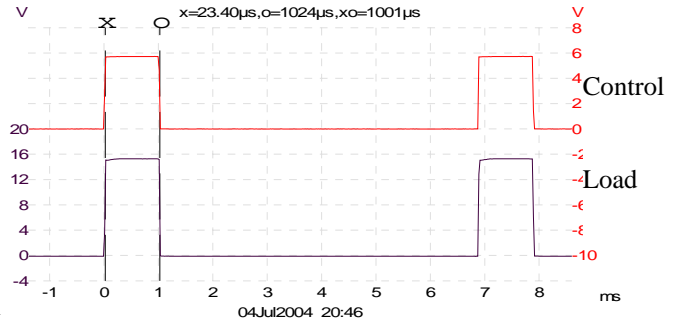
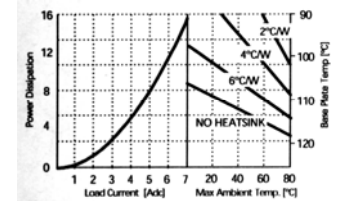
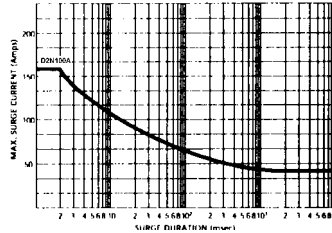

Pulse width 1mS, 500VDC, current 5A

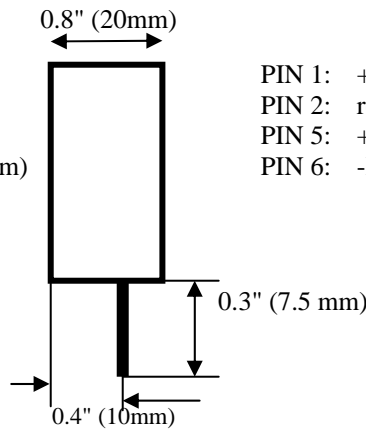
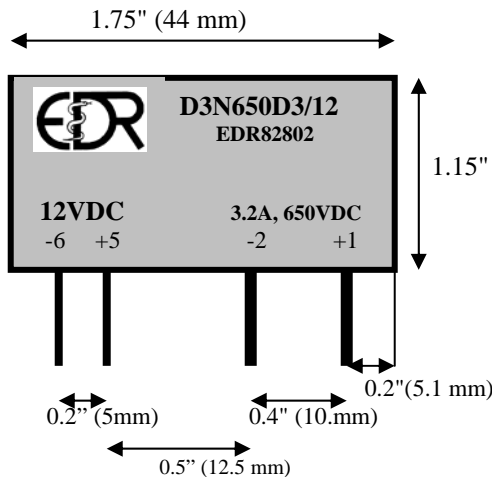

- PIN 1: + LOAD
- PIN 2: return LOAD
- PIN 5: +DC CONTROL
- PIN 6: -DC CONTROL

All Dimensions are in inches (millimeters).

Dimensions for SIP4 package 1.15"H x 1.75"L x 0.8"W
 Terminals/solder for SIP4 package control-0.40", power-0.6"

Transient Protection: All loads are inductive, even ones that are not so obvious or labeled. An inductive load produces a harmful transient voltage, which is much higher than the applied voltage, when it is turned on and off. A SSR built with a MOSFET output acts as an ideal switch and can produce a seemingly "non-inductive" load, which can cause damage if not suppressed. A transient voltage suppressor, which is bi-directional for AC applied voltage and unidirectional for DC applied voltage, should be used to clamp excessive spikes.

Electronic Design & Research Inc. ** 7331 Intermodal Dr. ** Louisville ** KY 40258

Tel: 502-933-8660; Fax: 502-933-3422; Sales: 800-336-1337; e-mail: vsholding@vsholding.com

Input Electrical Characteristics (Ta = 25°C) for D3N650D3/12, p/n EDR82802

Characteristic	Test Condition	Min	Typ.	Max.	Unit
Control voltage range		10	12	16	V
Maximum Turn-On Voltage			10		V
Maximum Turn-Off Voltage			8		V
Maximum Input Current			13		mA

Input Electrical Characteristics (Ta = 25°C) for D3N650D3/24, p/n EDR82806

Control voltage range		18	22	26	V
Maximum Turn-On Voltage			18		V
Maximum Turn-Off Voltage			16.8		V
Maximum Input Current			12		mA

I. Switching time test – Load – 625 Ohm & 0.8A, Control Signal – 24VDC & current 12mA

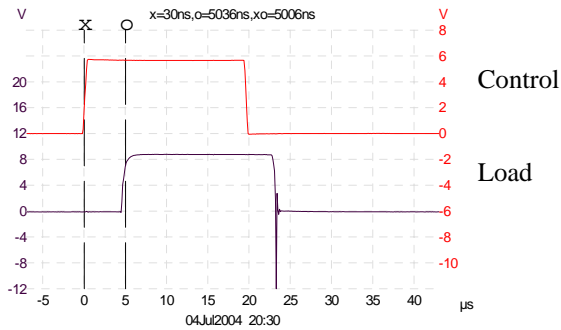

Figure 1 Turn-on delay is 5.0µS

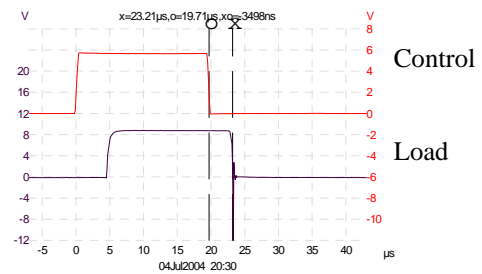

Figure 2 Turn-off delay is 3.5µS

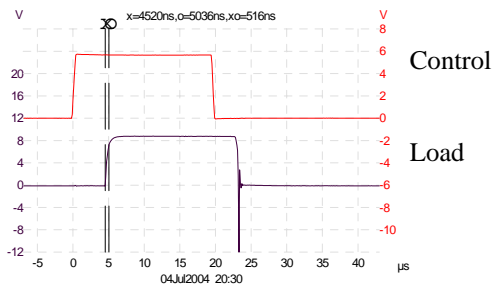

Figure 3 Rising Time is 0.516µS

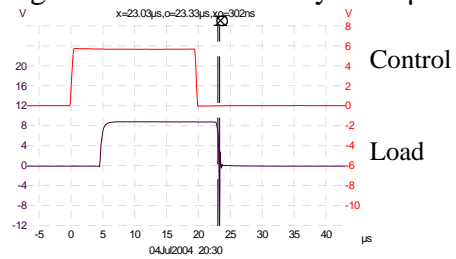

Figure 4 Fall Time is 0.302µS

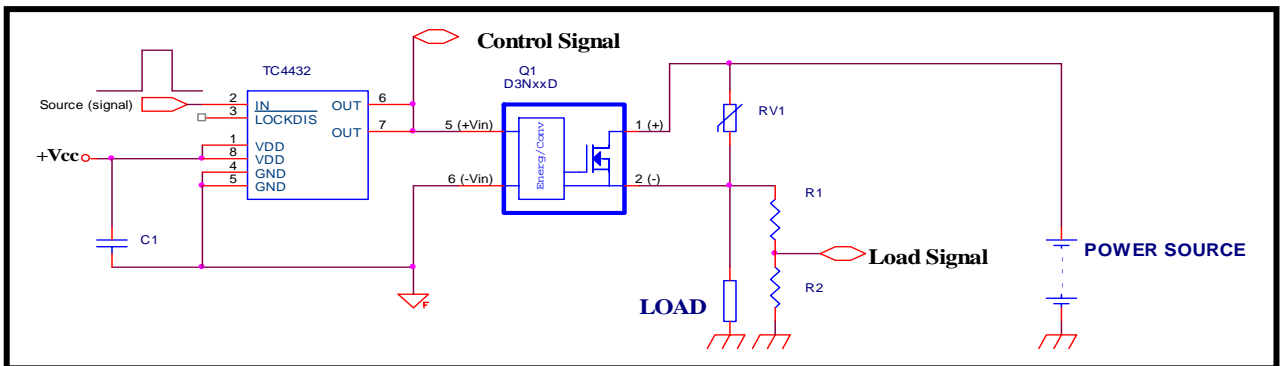

Figure 5 Switching Time Test Circuit

Electronic Design & Research Inc. ** 7331 Intermodal Dr. ** Louisville ** KY 40258

Tel: 502-933-8660; Fax: 502-933-3422; Sales: 800-336-1337; e-mail: vsholding@vsholding.com

Solid State Relay/Switch made by Electronic Design & Research

With respect to the growing needs for the replacement of low-speed, power-hungry and bulky electro-mechanical relays EDR Inc. has introduced several families of high-speed, powerful and inexpensive Solid State Relays (SSR) with MOSFETs and IGBTs on their outputs to control either DC, AC/DC or AC power. The advantages of a solid-state relay over an electromechanical relay are well described in modern publications. These include the absence of moving parts to wear out, no acoustical noise, low controlling power, no contact bounce or arcing, minimal space requirements and a long life expectancy. Mostly the high-power, DC and DC/AC types of SSR's cost less than the comparable electromechanical relay. The situation is different for low power AC-type electromechanical relays. These can cost, in some cases, much less than a SSR. The choice might look obvious. Though some simple calculations that take into consideration a relay's life expectancy, the cost of replacements, shipping expenses, loss of production time, and the labor cost of replacing a worn out relay makes a SSR the prime choice in new designs and retrofits.

Since 1997, our company has been concentrating on developing the most advanced Solid State Relays and Breakers, which have opened the door of opportunity for technological improvements in many fields of industry. Our innovations have drastically improved Solid State Relays and have expanded their applications. For an example, a MOSFET-based AC-type relay finds application in the airline industry where the heat generated by a TRIAC-based relay and its size became the obstacle in achieving high reliability and energy concerns. Our AC-type relay (D1N200A3) wastes only 0.080W and that is twenty times less than a TRIAC-based relay made by CRYDOM (D2W203) which wastes 1.5W at a load of 1A rms.

Solid State Relays manufactured by EDR fall into one of the following categories:

1. Direct driving, super-low cost, comparable to the speed of an electromechanical relay
2. Direct driving, medium speed and medium cost
3. With a built-in DC/DC converter and independent controls, high-speed and medium cost
4. Direct driving, super-fast type that is capable of delivering 400Amps in a microsecond

Along with SSRs, we manufacture a Solid State Power Controller (SSPC) or an AC/DC Intelligent Solid-State Relay/Breaker (iSSR/Breaker) to be used in Aircraft and Naval applications. This DPST (double pole, single throw) module (EDR82360) has integrated sensing capabilities to protect itself from over current and over temperature while exhibiting the properties of a time-delay fuse. Electronically controllable for faster and more reliable power management, the EDR82360 was designed to replace 4 components: an electromechanical or SSR relay, a switch, and a fuse holder with a fuse.

EDR's Solid State Relays and Breakers are potted in a thermally conductive epoxy for optimal performance in today's very demanding industrial and military environments. Most relays are produced in four popular sizes: D1-type (0.6"H x 1.0"L x 0.3"W), D2-type (1.15"H x 1.78"L x 0.4"W), D3-type (1.15"H x 1.78"L x 0.8"W) and D4-type (1.15"H x 2.0"L x 0.9"W) with currents ranging from 3A up to 76A and voltages from 30V to 1,700V. These relays have configurations with SPST, DPST, 3PST or TOTEM outputs. We do not charge a set-up fee for a custom specified relay for orders of 250 or more.

Some of our customers are,

Lockheed Martin/Naval Electronics & SSUS
Metal Action Inc.
3M Co
Aerojet Corp
Flight Refueling Limited/Military System Division
iWerks Entertainment, Inc
TDG Aerospace Inc., etc.
Bell Electronics Ceramic Inc.
HP

Our customers use EDR's relays and circuit breakers in a wide variety of highly critical applications. They are also used in everyday industrial applications to control DC&AC Motors and solenoids on production lines. Our intelligent SSR/Breaker (p/n EDR82360) controls AC/DC power distribution in super-servers on submarines. Our SSR/Switches test high-speed solenoids to be used in

Aviation, they distribute AC/DC power in the cockpits of airplanes, control air-valves to activate the movement of chairs in iMax Theaters, deliver 20KW in a few microseconds for laser research and numerous other applications. Our MOSFET-based, AC-type, miniature and super low power consumption relays found applications in the power distribution on airplanes.

Notes on Operation, Driver and the Requirements for a Driving Signal

For the best performance, remember that EDR's High-Speed Solid State Relay/Switch (SSR/S) have important input and output requirements. To avoid degradation of the turn-on and turn-off delays and maximum switching speed the driver signal must be equal to the nominal voltage and have fast turn-on and turn-off slopes. A SSR is capable of switching zillions of times without any degradation and the long-life expectancy can be achieved if it is protected against harmful transient voltages. In most cases, a snubbing (R-C) network would bring a positive result. A transient voltage suppressor (TVS) could be a better choice. In this case, power dissipation must be calculated or obtained empirically if high frequency chopping is the application.

The SSR's best performance can be simply achieved by utilizing one of four types of DIN RAILS made by EDR. Our DIN RAIL mounting assemblies are available to fit a wide variety of industrial modules, such as IOC, ODC, D2W, CX, CMS and any of the D2N & D3N SSR packages made by EDR. These DIN modules provide excellent isolation, above 3000V, between the interfacing circuitry and field devices. They are designed to accommodate high power and high-speed SSRs and control up to 14Amps on the standard model and 28Amps for more power-hungry applications. There are four types of DIN RAIL assemblies are available:

1. Direct driving with a LED to indicate the presence of the control signal (EDR82555),
2. With a driver and optional de-bouncing circuitry (EDR82558 and EDR82558/D respectfully) for better noise and bouncing rejections,
3. With a high-speed driver for applications such as the ability to enable the delivery of a very short burst of power, PWM and other high frequency applications (EDR82603),
4. With a built-in latchable driver (EDR82604) for easy interfacing with the push-on and push-off type of industrial applications.

A customer made driver

EDR's relays and breakers are designed to be soldering to a PC board directly or plugged into a socket. Below are several recommended schematics for customers who want to design a relay driver. Though some SSRs functionally resemble an electromechanical relay, but they are built completely differently and demanding a better care of a circuit that drives them. The similarities being each having two terminals on the input for the control voltage and two terminals on the output for the load. This is especially true for EDR's high-speed SSRs built with a direct driving input. That family of SSR's is built with transformer-coupled devices and the input circuitry is a high-frequency generator/converter with an R-C filter on its input. A SSR consumes very little power, on average about 200mW (10mA at 20VDC). The turning on transition is quite a different story due to the built-in R-C filter. For a short moment, during the few microseconds the input current may peak up to 0.8A during a turn-on cycle. That specification makes a low power MOSFET the prime choice as the relay driver.

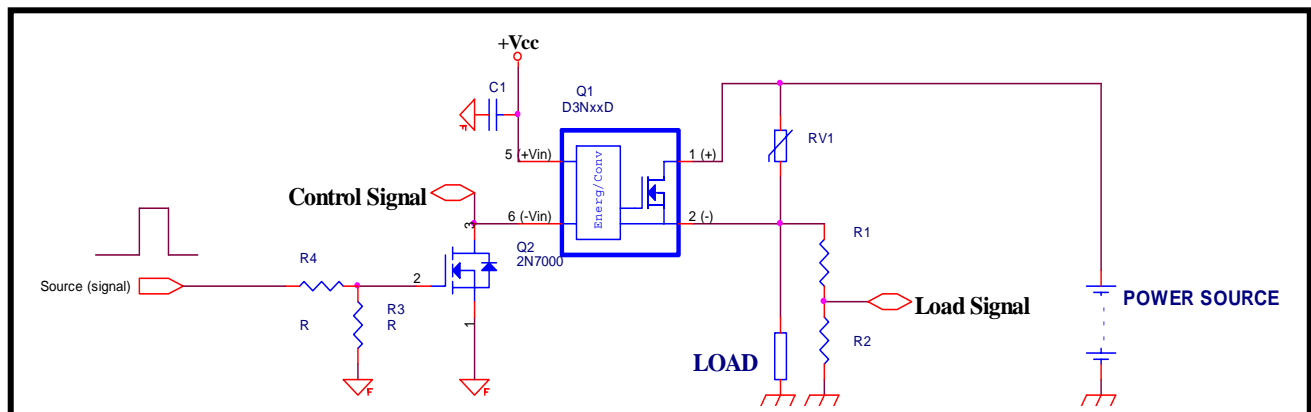

Figure 7 Driving a SSR/S with a MOSFET

For low-speed and non-critical applications, a simple push-button switch or any other mechanical device such as an electromechanical relay (EMR), toggle switch, etc. can be used directly to control a SSR/S. A switch (SW1) can be used on the low side as shown in Figure 5 or the high side of Vcc. It is not the best way to control the SSR/S and we could recommend such control only for EDR's low-speed SSRs.

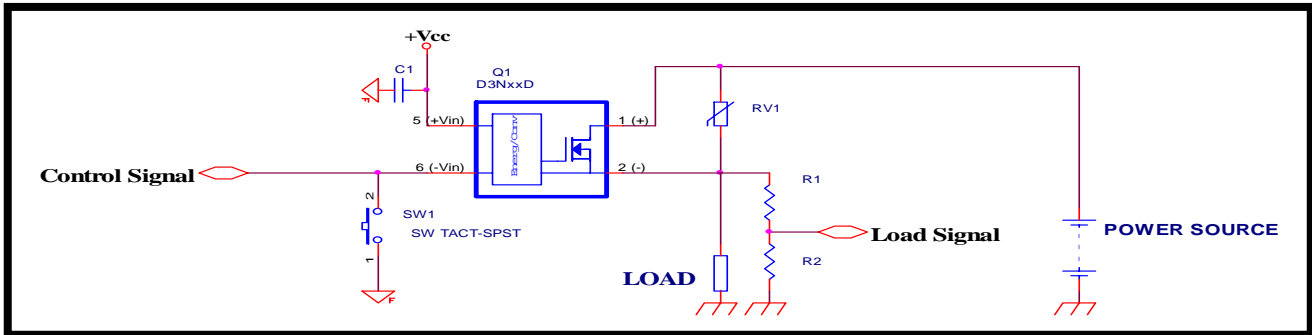

Figure 8 A bush-button controls a high-speed SSR/S

We offer a DIN RAIL (p/n EDR82555) without a driver for applications when cost is the main concern and when a customer wants to use their own driver or just an external switch. We do not recommend a mechanical switch to drive a high-speed SSR. The bouncing nature of a mechanical switch, including an EMR, would be transferred onto the SSR's output. De-bouncing circuitry must be used to avoid such a problem and a DIN RAIL (p/n EDR82558, see in Fig. 6, below) can be the best choice for industrial applications. A DIN RAIL (p/n EDR82604) with a latchable driver will help to solve bouncing. If a customer decided to build their own driver we recommend to use the same or similar schematic solution.

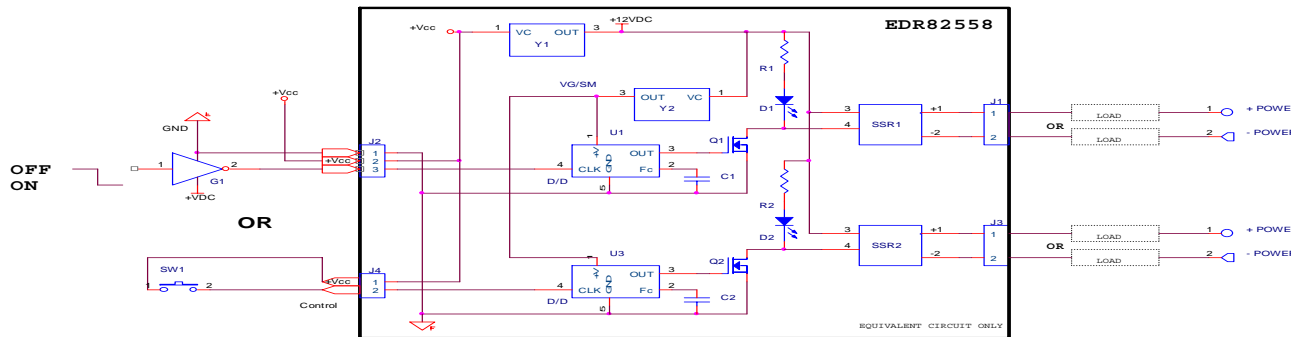

Figure 9 EDR's DIN RAIL (p/n EDR82558)

High-speed Application p/n EDR82603 could be the prime choice

EDR's Solid State Relay/Switch has opened the door of opportunity and technological innovation in many fields of industry. Our SSR/Ss have being employed to test high-speed solenoids, delivery a high-power pulse in metal lithography, control air-valves, etc. In those applications, overall high performance can be obtained without a proper relay driver. It may be surprising that the solution is available today. Nowadays several companies make a dedicated MOSFET driver. That could be the best choice especially for high speed chopping and delivering a short, high power pulse.

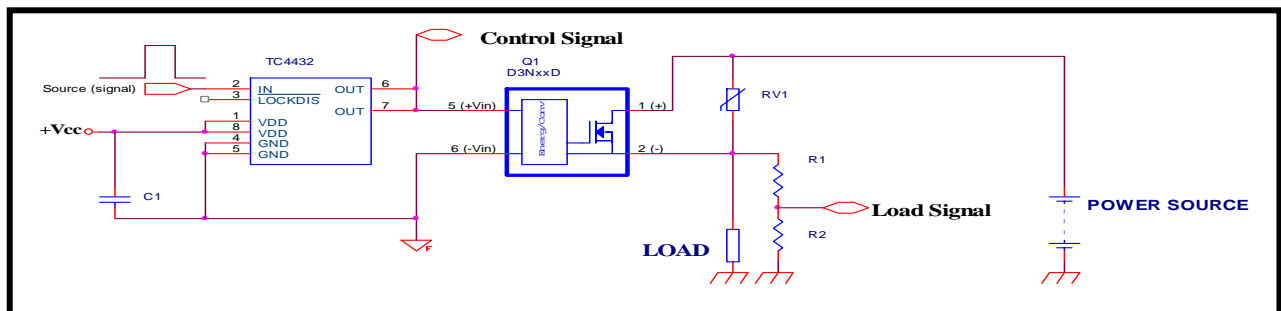

Figure 10 A high-speed Solid State Relay is controlled by a dedicated MOSFET driver.